

Fruit Shop Sheet 1

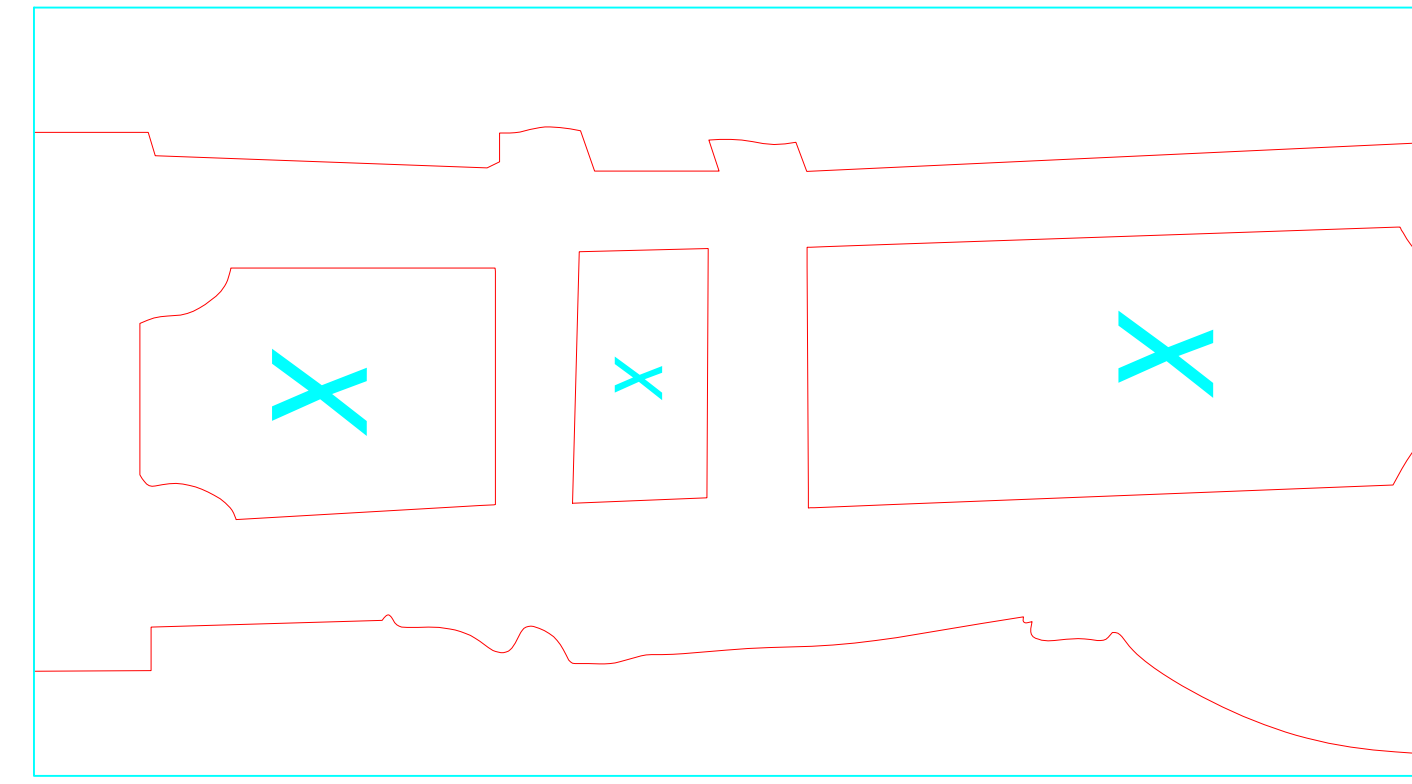

Boarding House Sheet 2

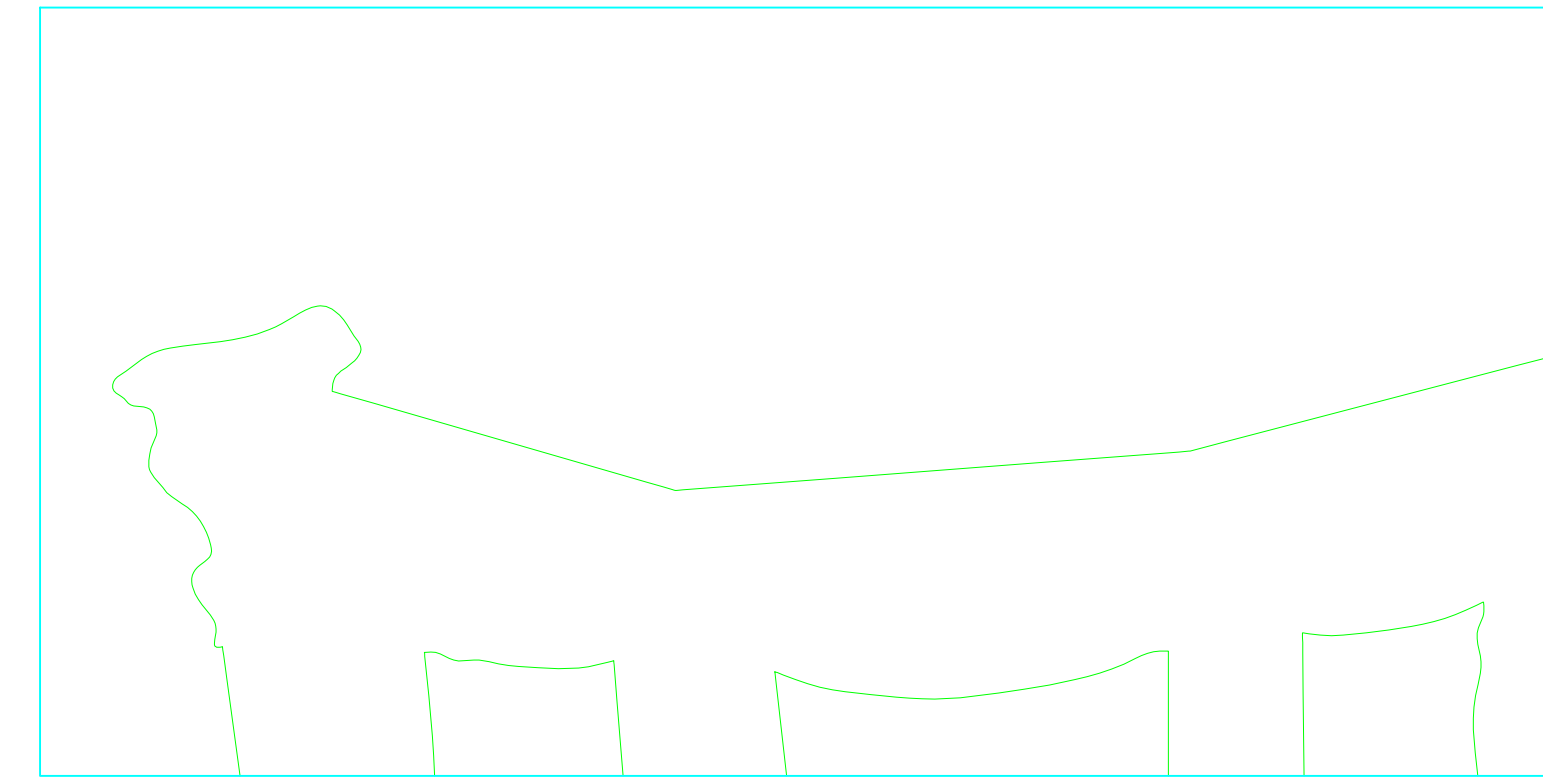

Cliff's Room Sheet 1

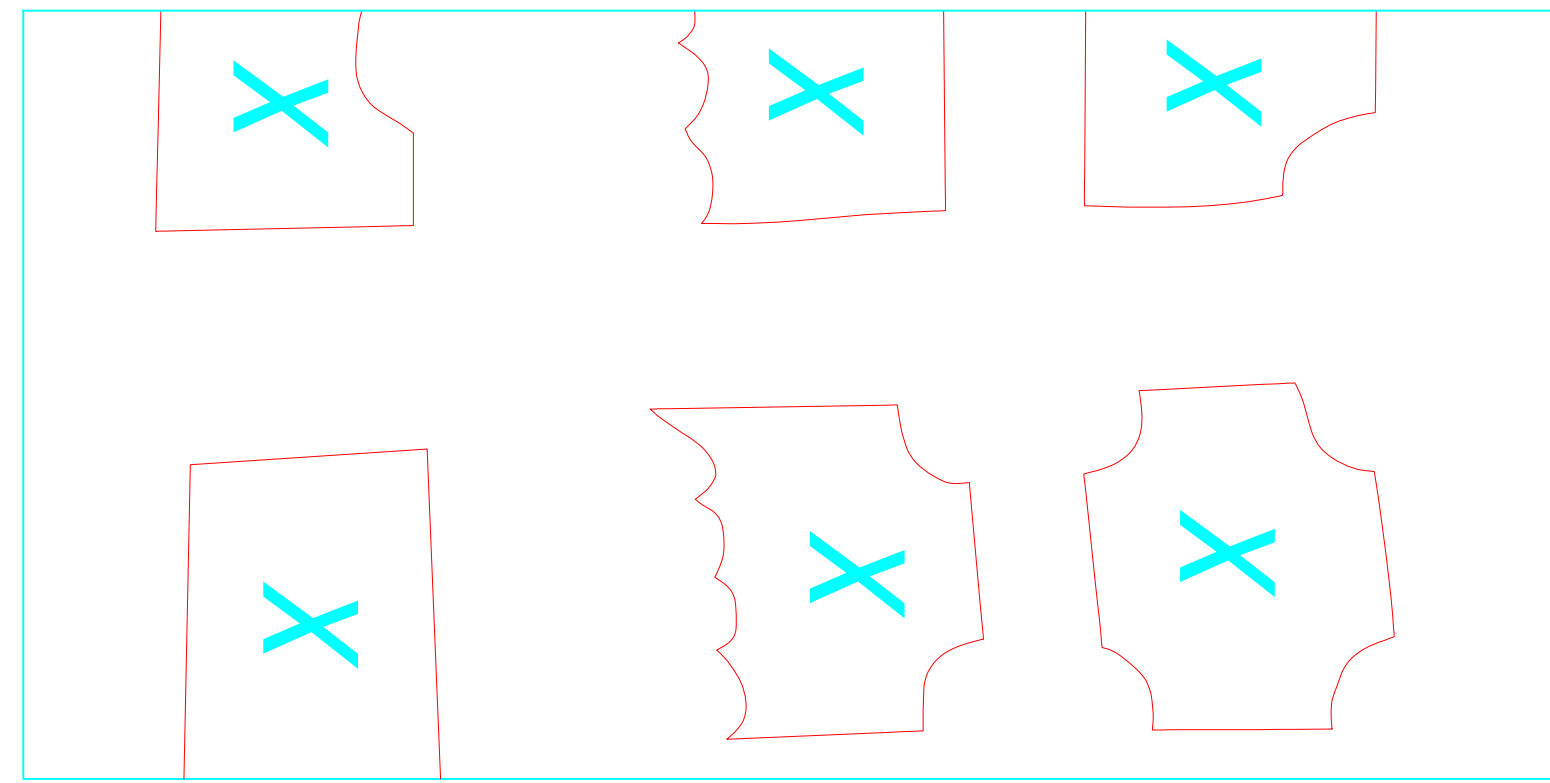

Fruit Shop Sheet 2

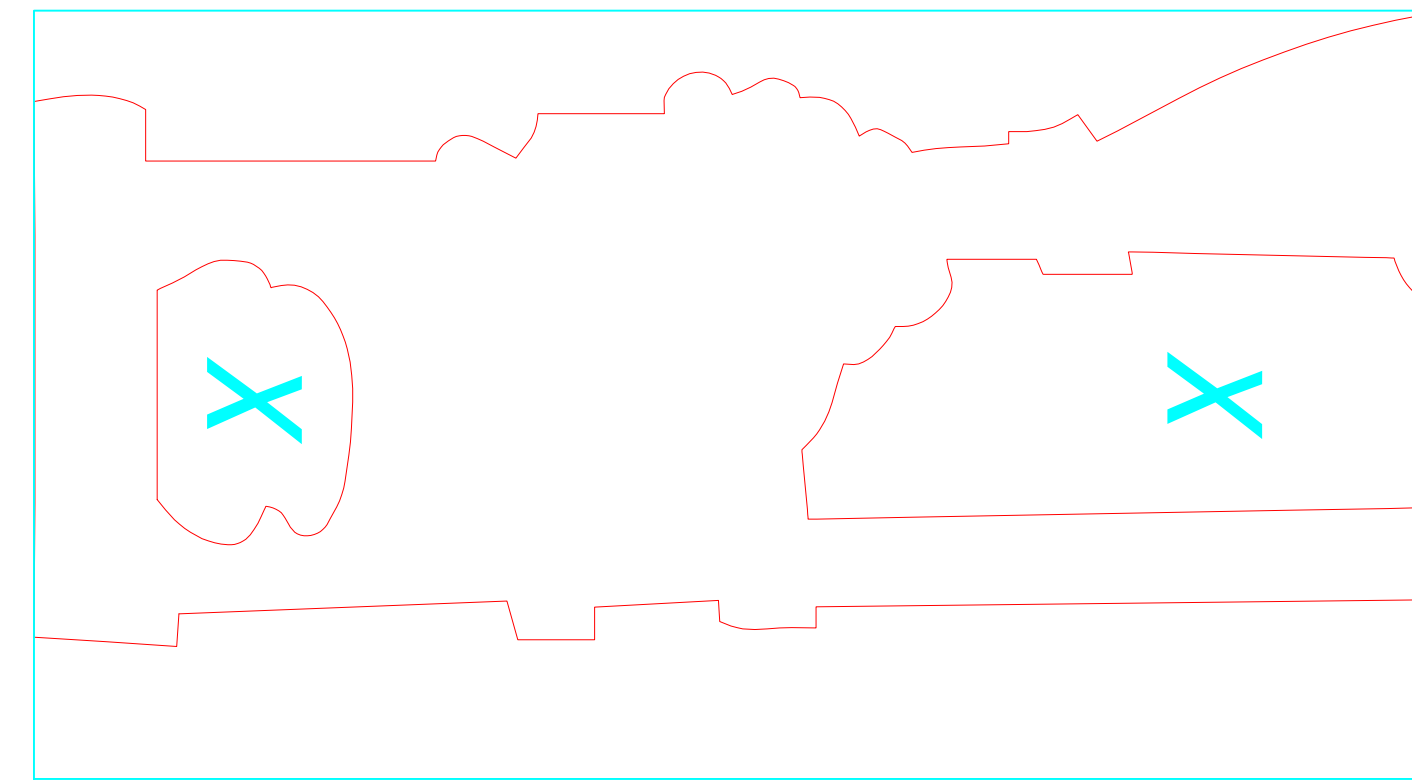

Boarding House Sheet 3

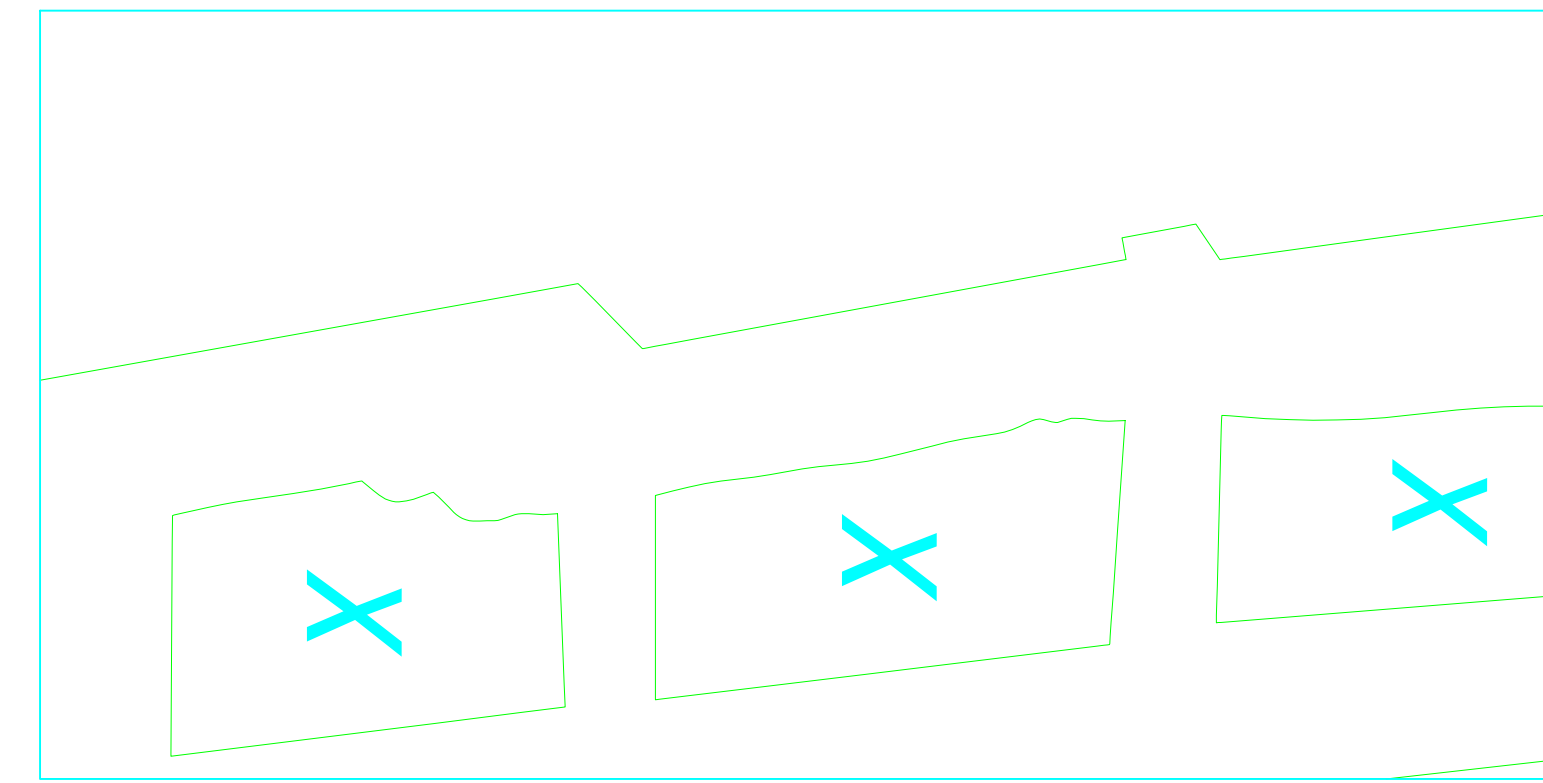

Cliff's Room Sheet 2

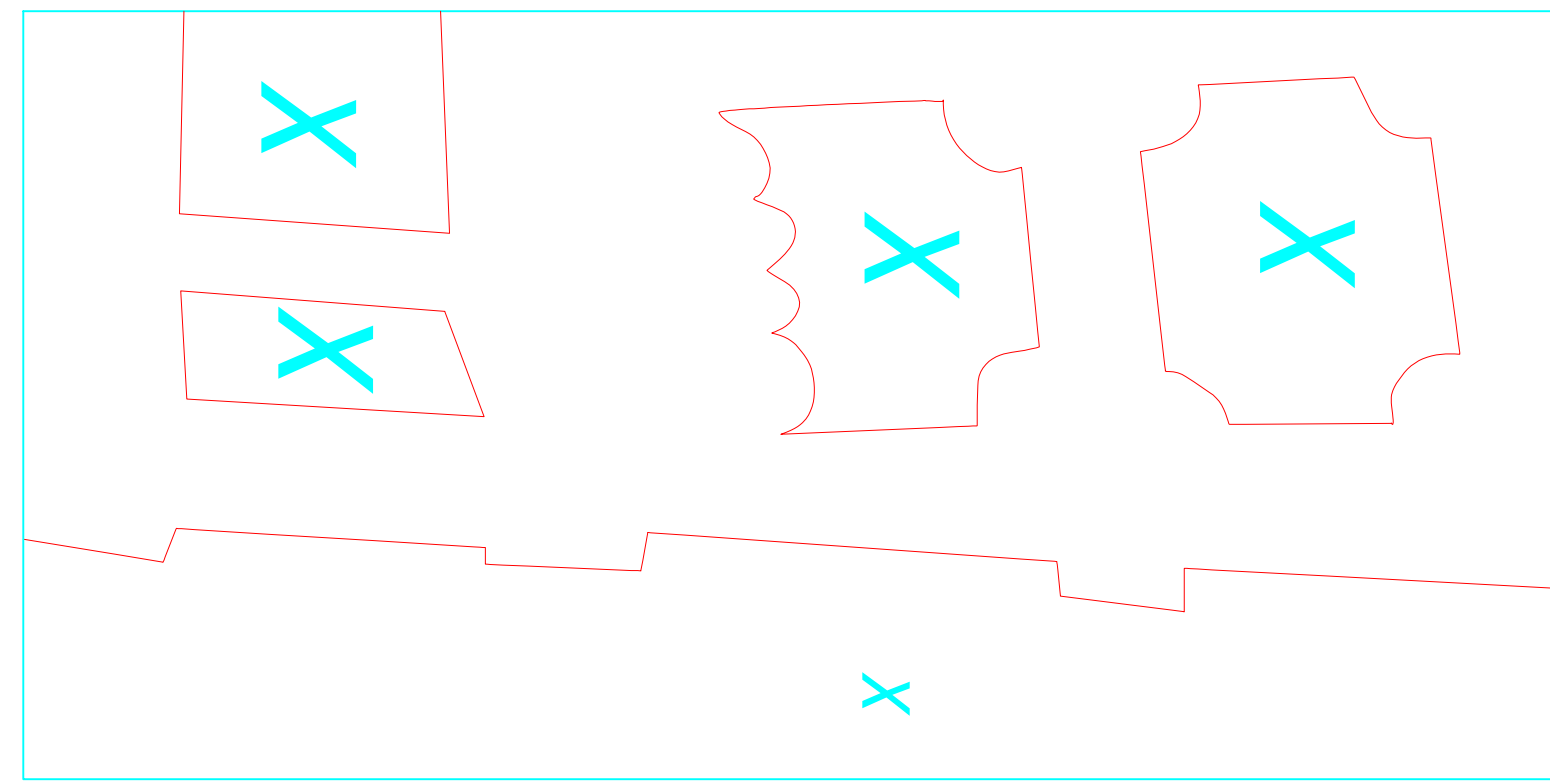

Fruit Shop Sheet 3

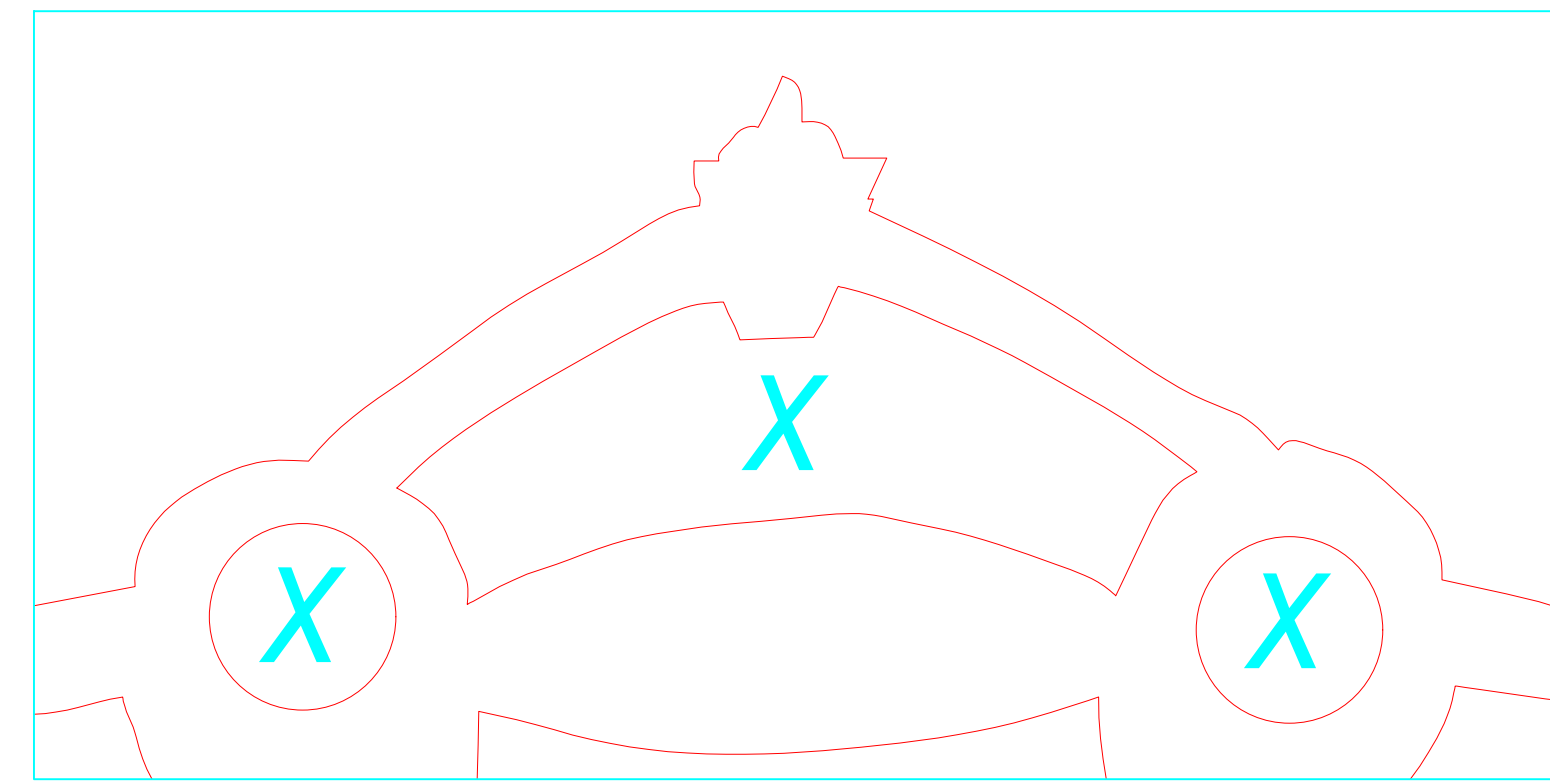

Boarding House Sheet 4

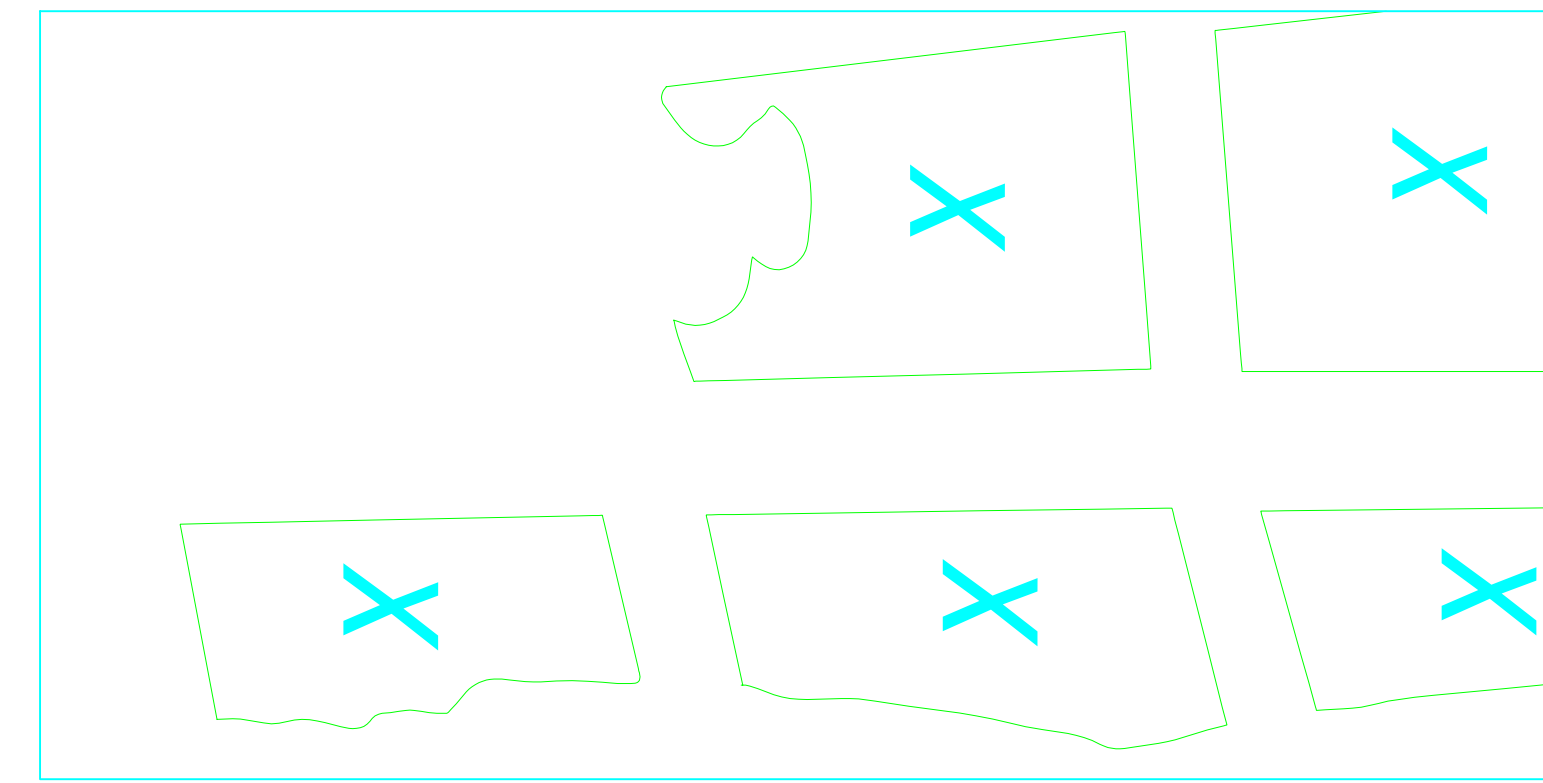

Cliff's Room Sheet 3

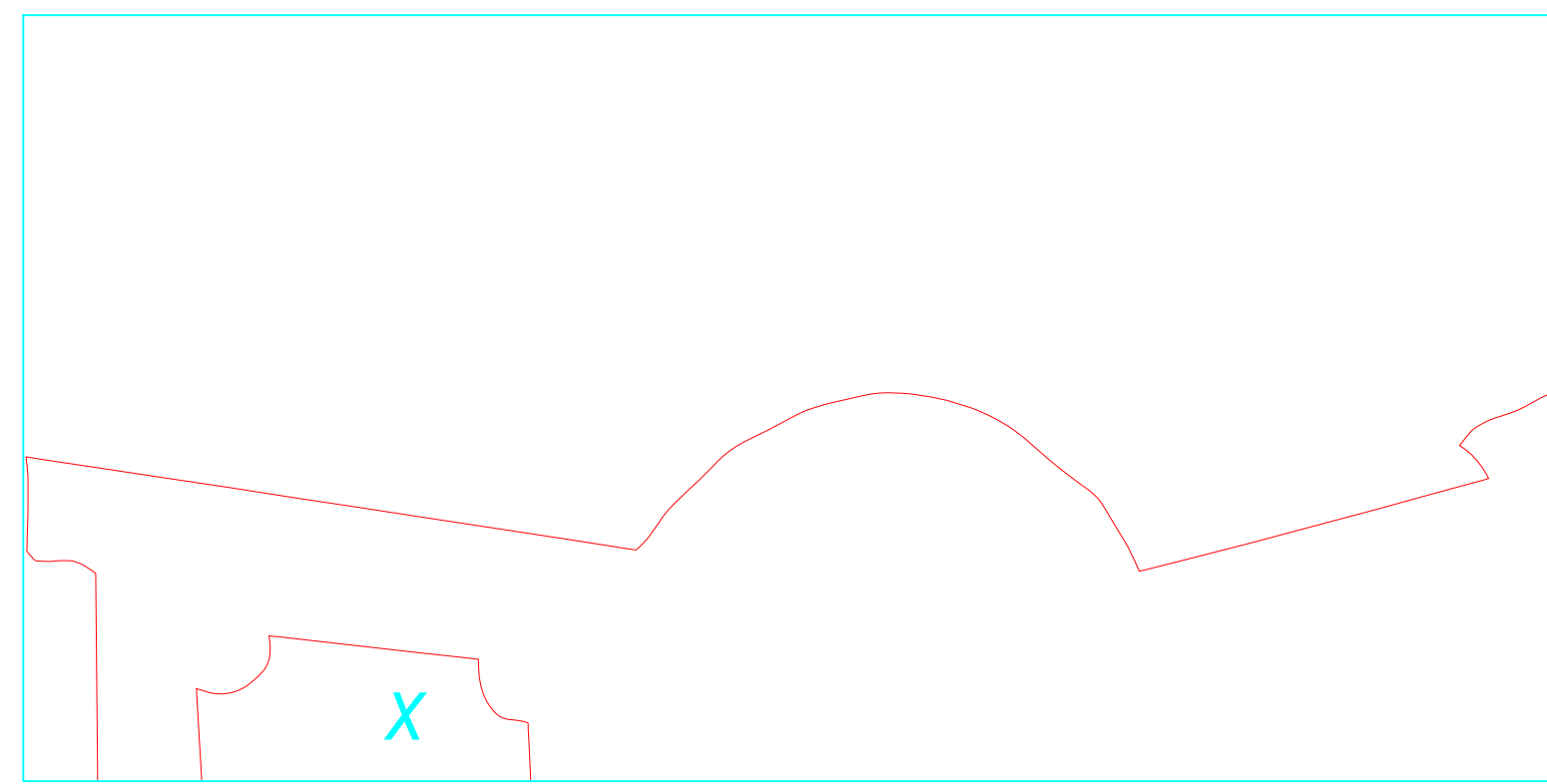

Fruit Shop Sheet 4

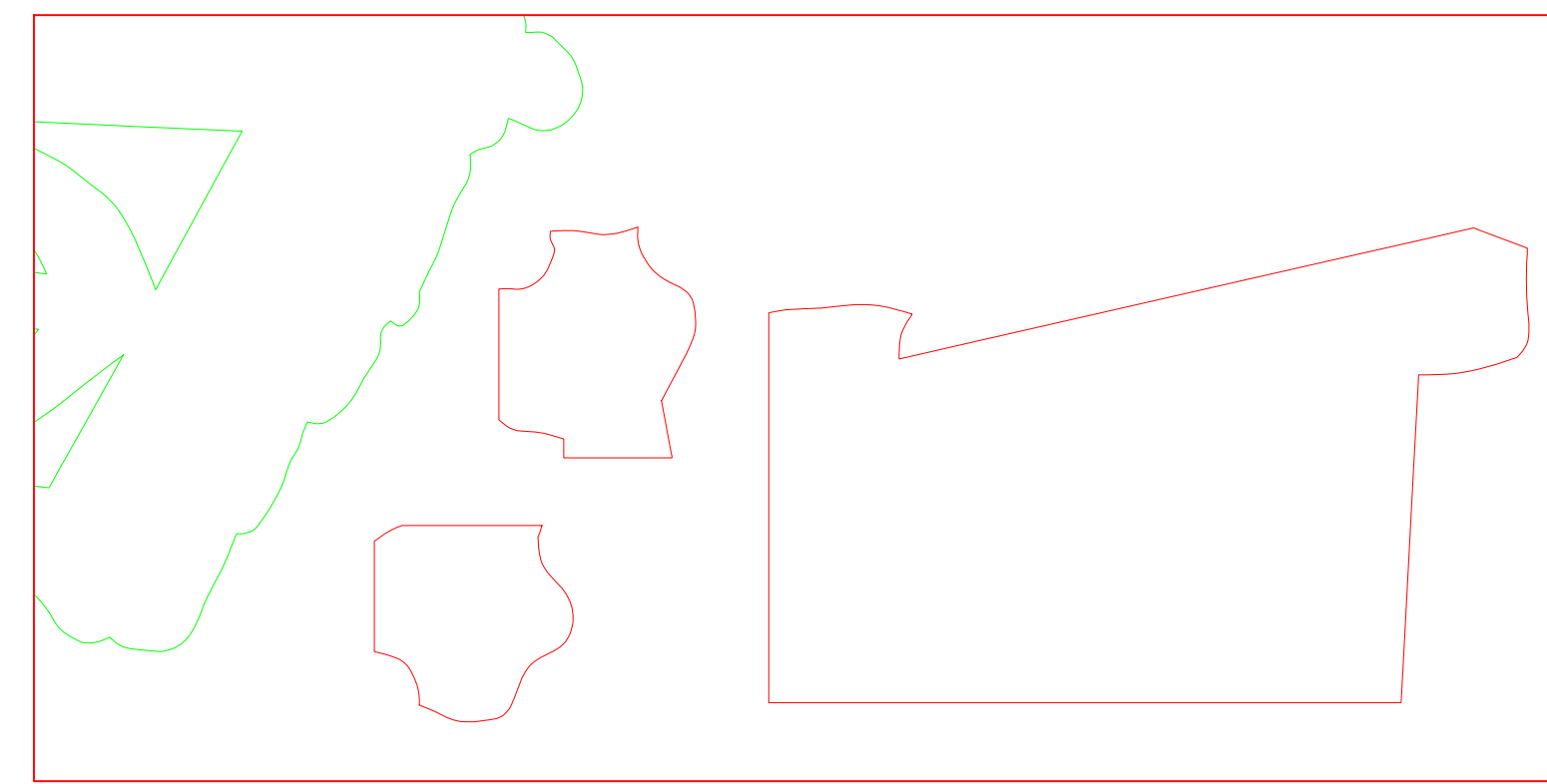

Boarding House Sheet 1
Cliff's Room Sheet 5

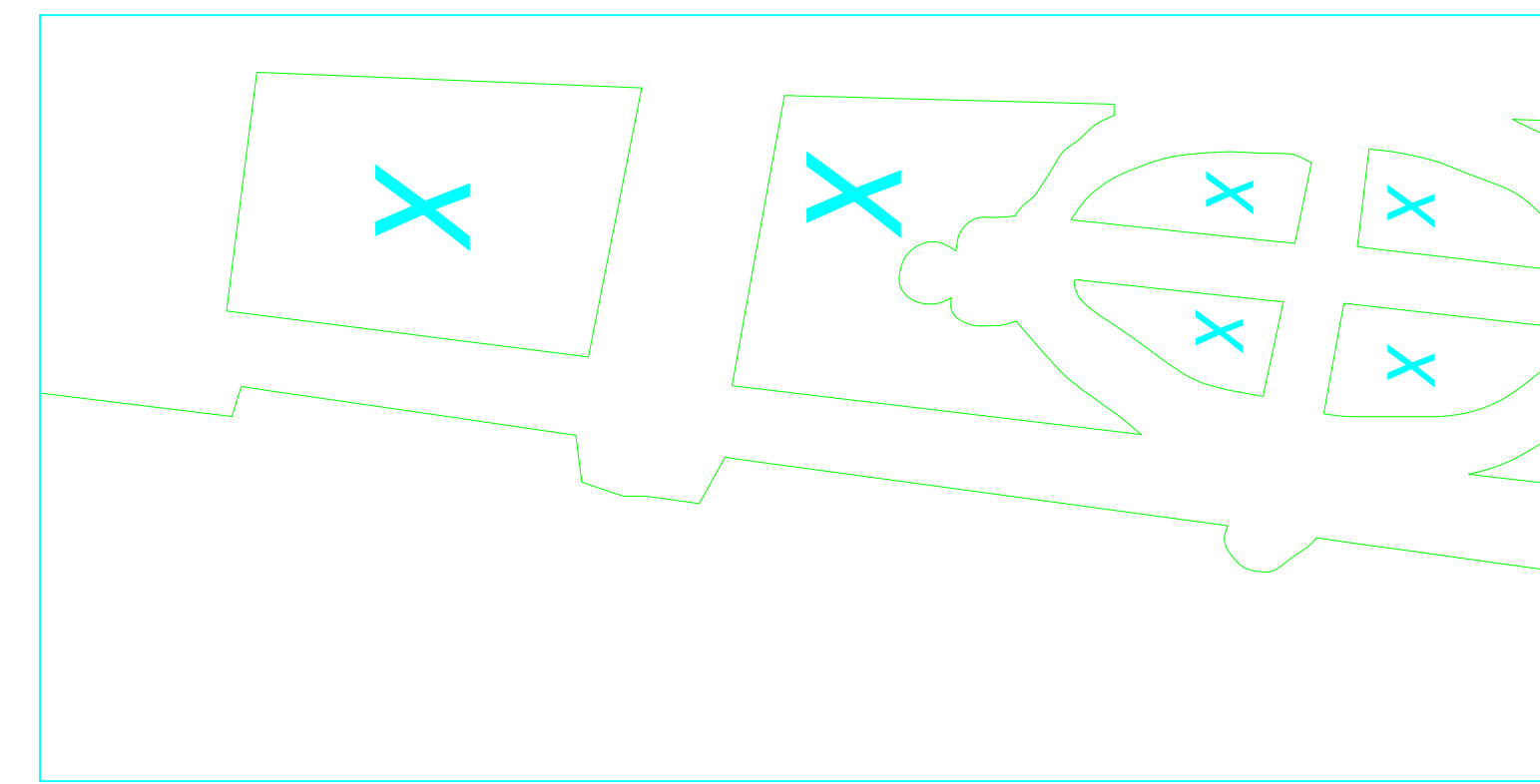

Cliff's Room Sheet 4

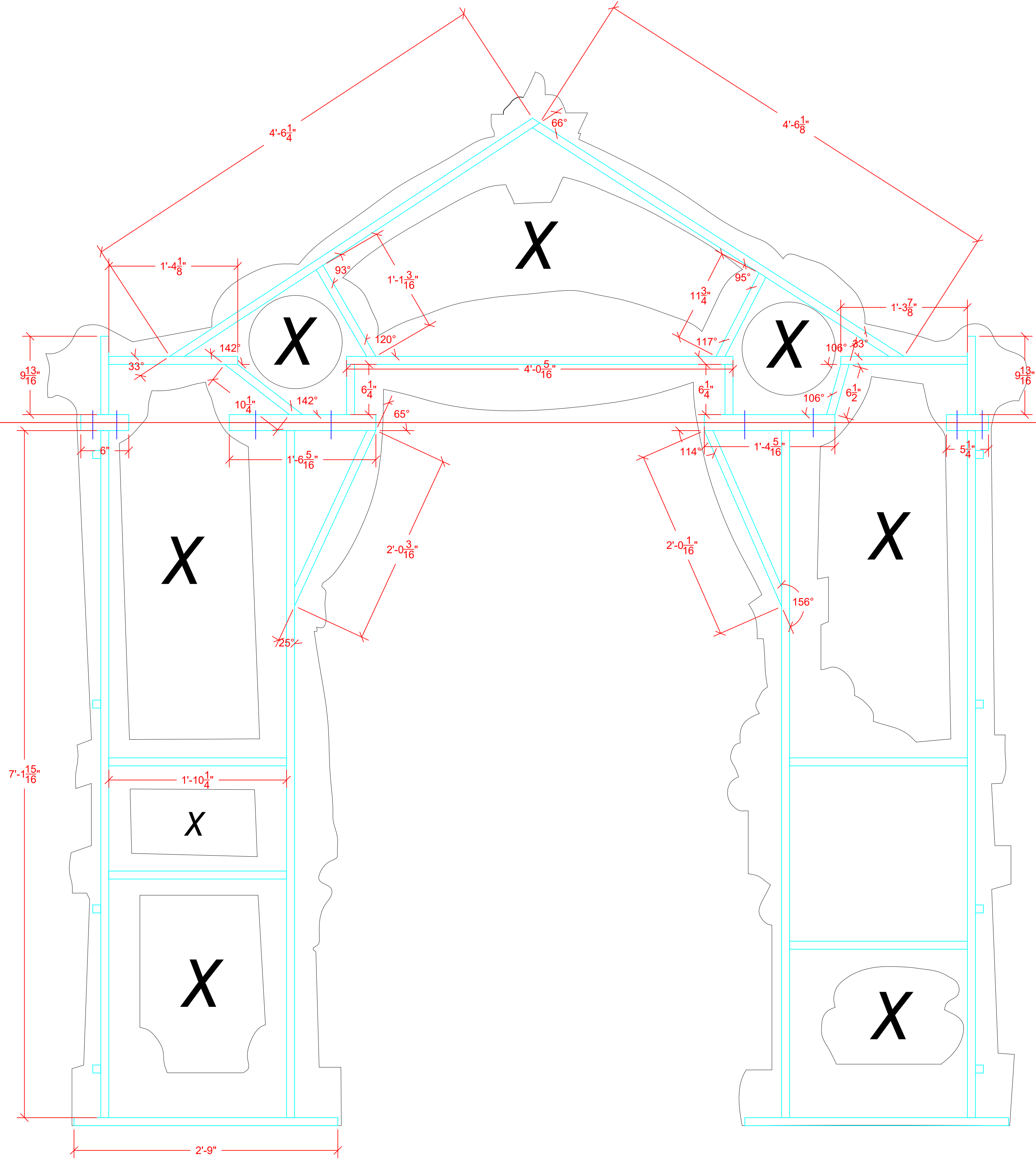

CABARET

Betts

Boarding House Flat

Scale:

1 1/2" = 1'

Director:

Gerrad A. Taylor

Date Drawn:

2/14/2022

Designer:

Michael Stepowany

Date Completed:

Draftsman:

Abby Bender

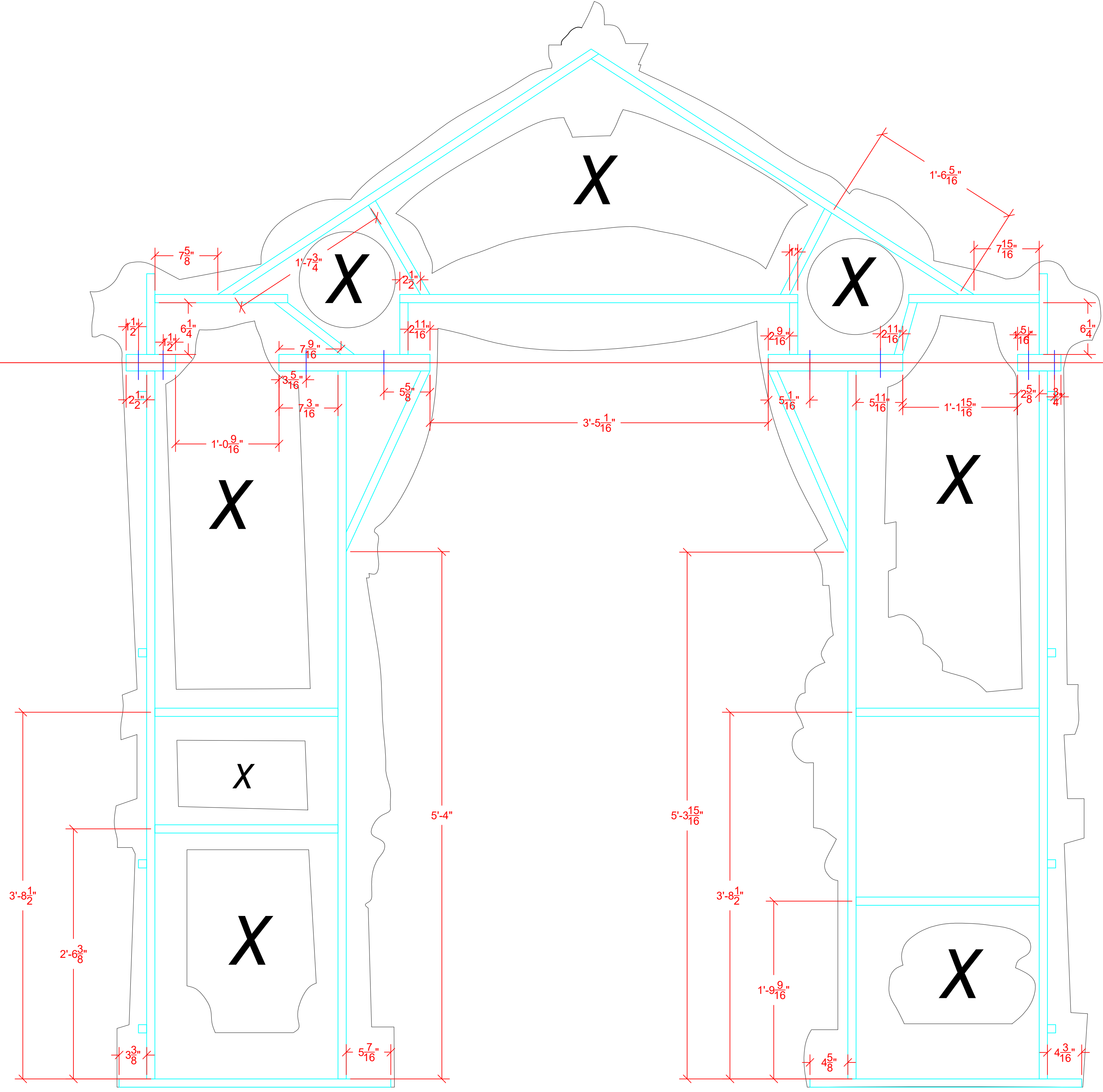

CABARET

Scale:

1 1/2" = 1'

Director:

Gerrad A. Taylor

Betts

Date Drawn:

Designer:

Michael Stepowany

Boarding House Flat Spacing

Date Completed:

Draftsman:

Abby Bender

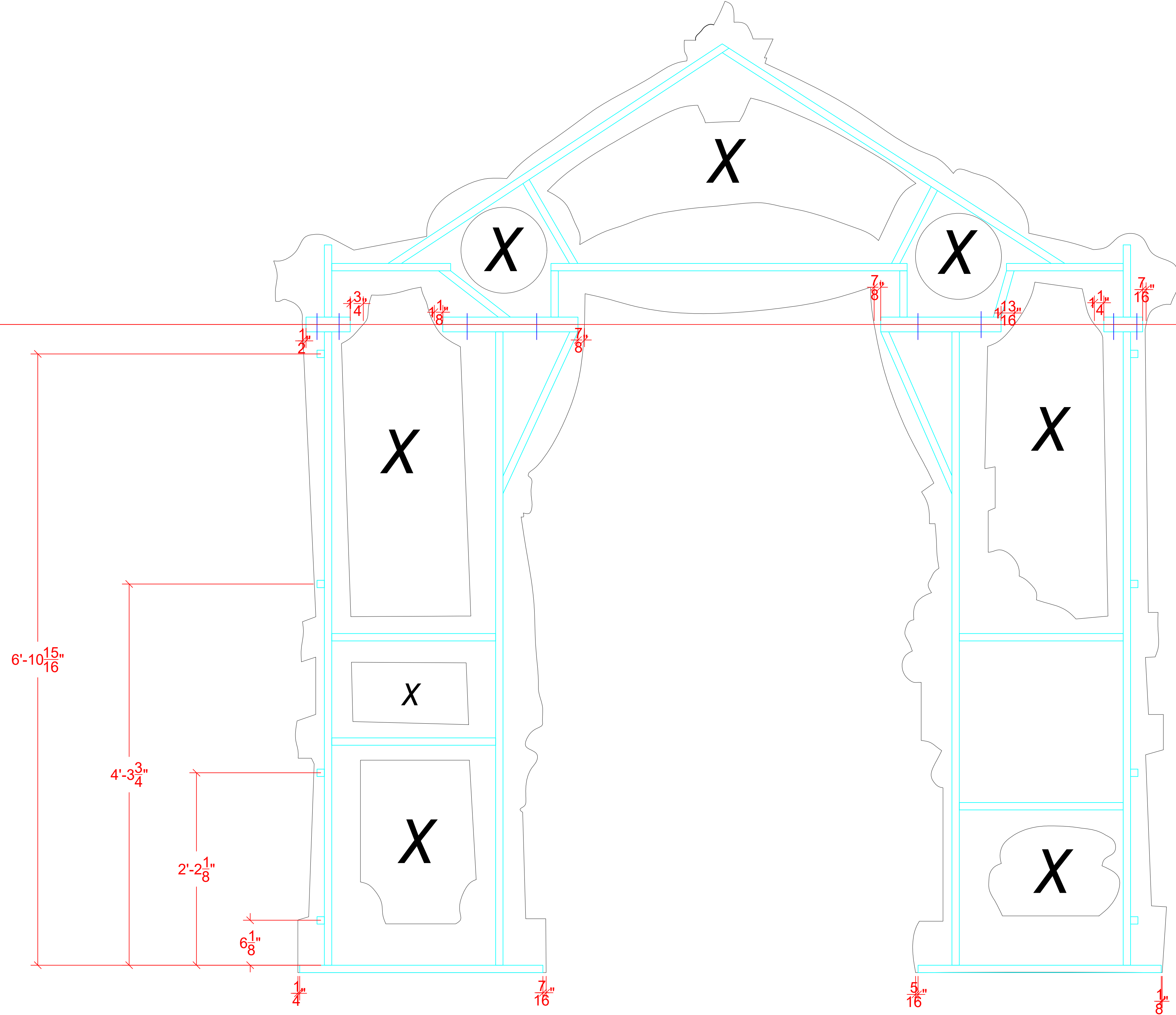

CABARET

Scale:

1 1/2" = 1'

Director:

Gerrad A. Taylor

Betts

Date Drawn:

Designer:

Michael Stepowany

Boarding House Flat Spacing

Date Completed:

Draftsman:

Abby Bender

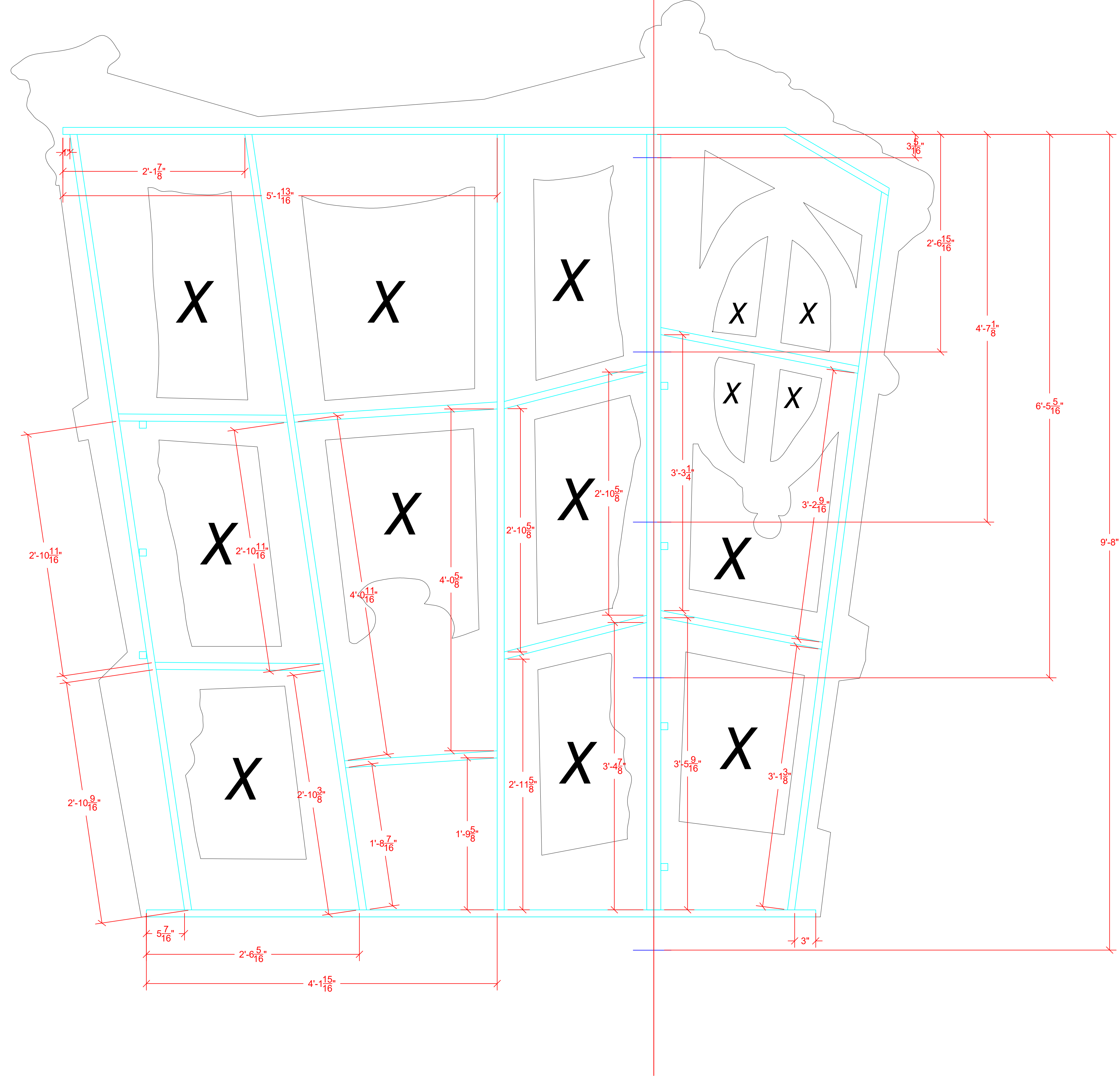

CABARET

Betts

Cliff's Room Flat

Scale:

Date Drawn:

Date Completed:

1 1/2" = 1' Director:

2/15/2022 Designer:

Draftsman:

Gerrad A. Taylor

Michael Stepowany

Abby Bender

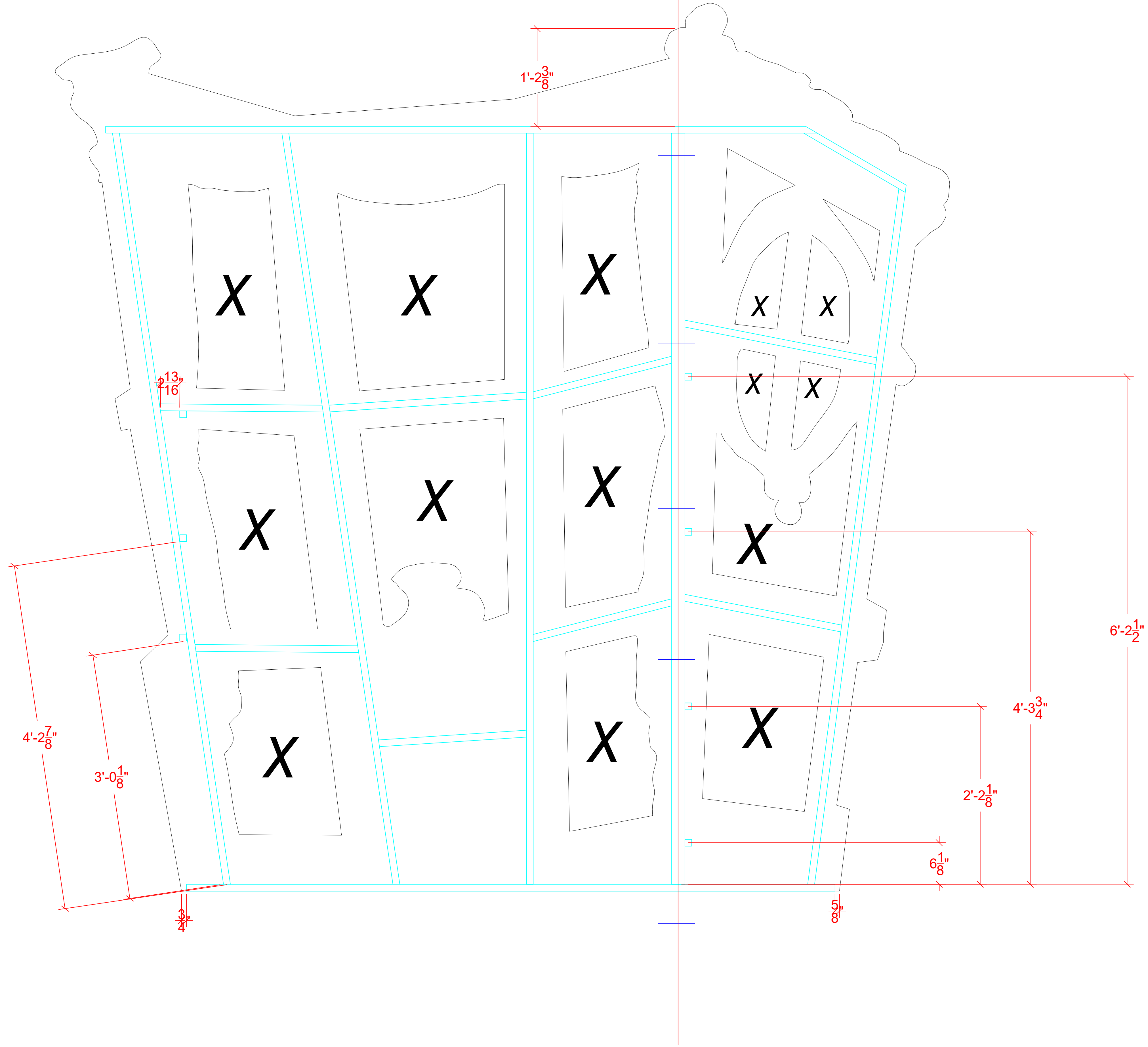

CABARET

Betts

Cliff's Room Flat

Scale:

1 1/2" = 1'

Director:

Gerrad A. Taylor

Date Drawn:

2/15/2022

Designer:

Michael Stepowany

Date Completed:

Draftsman:

Abby Bender

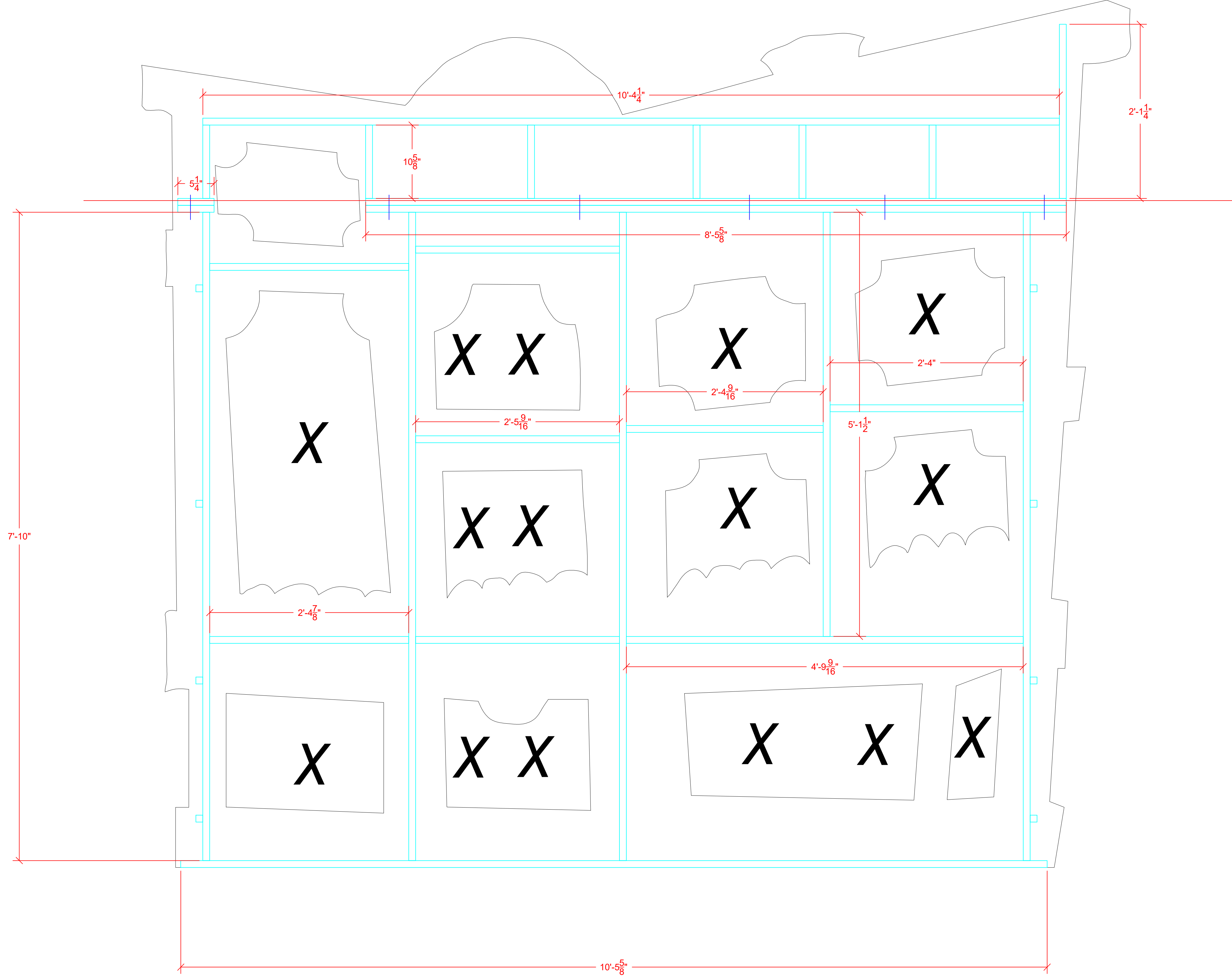

CABARET
Betts
Fruit Shop Flat

Scale:

Date Drawn:

Date Completed:

1 1/2" = 1' Director:

2/15/2022 Designer:

Draftsman:

Gerrad A. Taylor

Michael Stepowany

Abby Bender

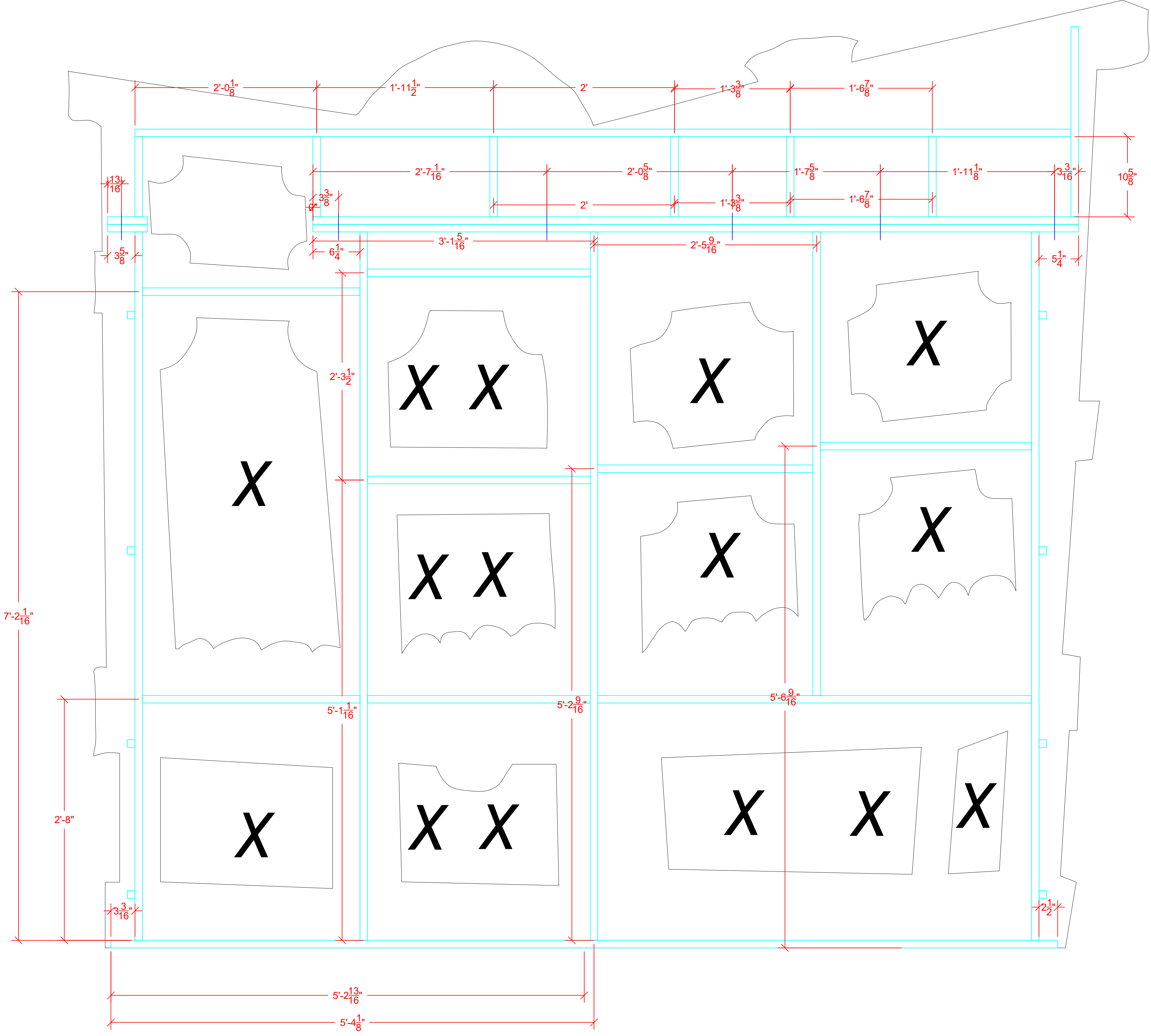

CABARET
Betts
Fruit Shop Flat

Scale:

1 1/2" = 1'

Director:

Gerrad A. Taylor

Date Drawn:

2/15/2022

Designer:

Michael Stepowany

Date Completed:

Draftsman:

Abby Bender

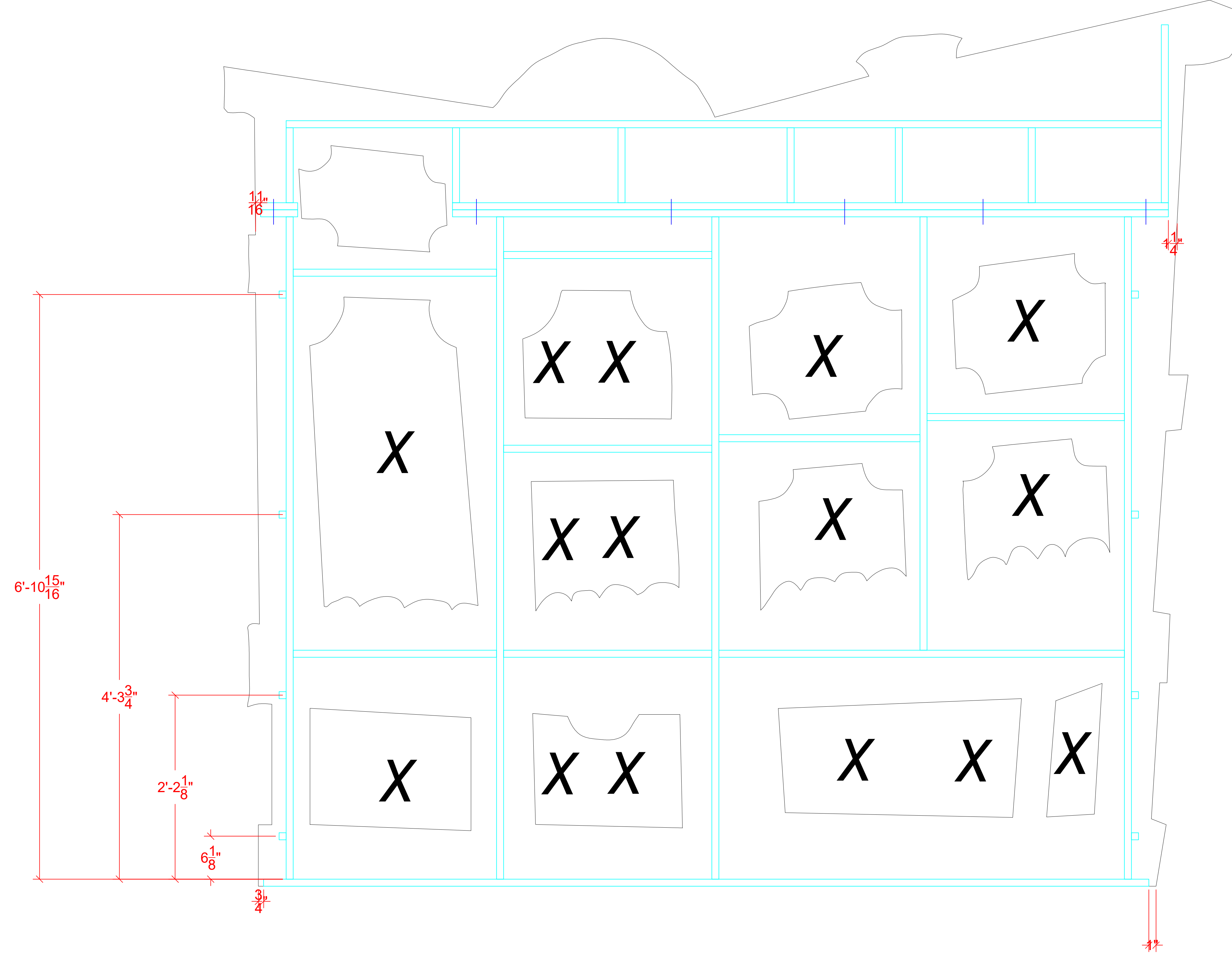

CABARET

Betts

Fruit Shop Flat

Scale:

1 1/2" = 1'

Director:

Gerrad A. Taylor

Date Drawn:

2/15/2022

Designer:

Michael Stepowany

Date Completed:

Draftsman:

Abby Bender

CABARET Flat Jacks- MAKE 6

1" box tube construction

Green represents 4" x $\frac{1}{4}$ " flat stock for caster plates- center and drill holes as appropriate

Holes will be added based on placement of angle iron on flat frames (see second drawing)

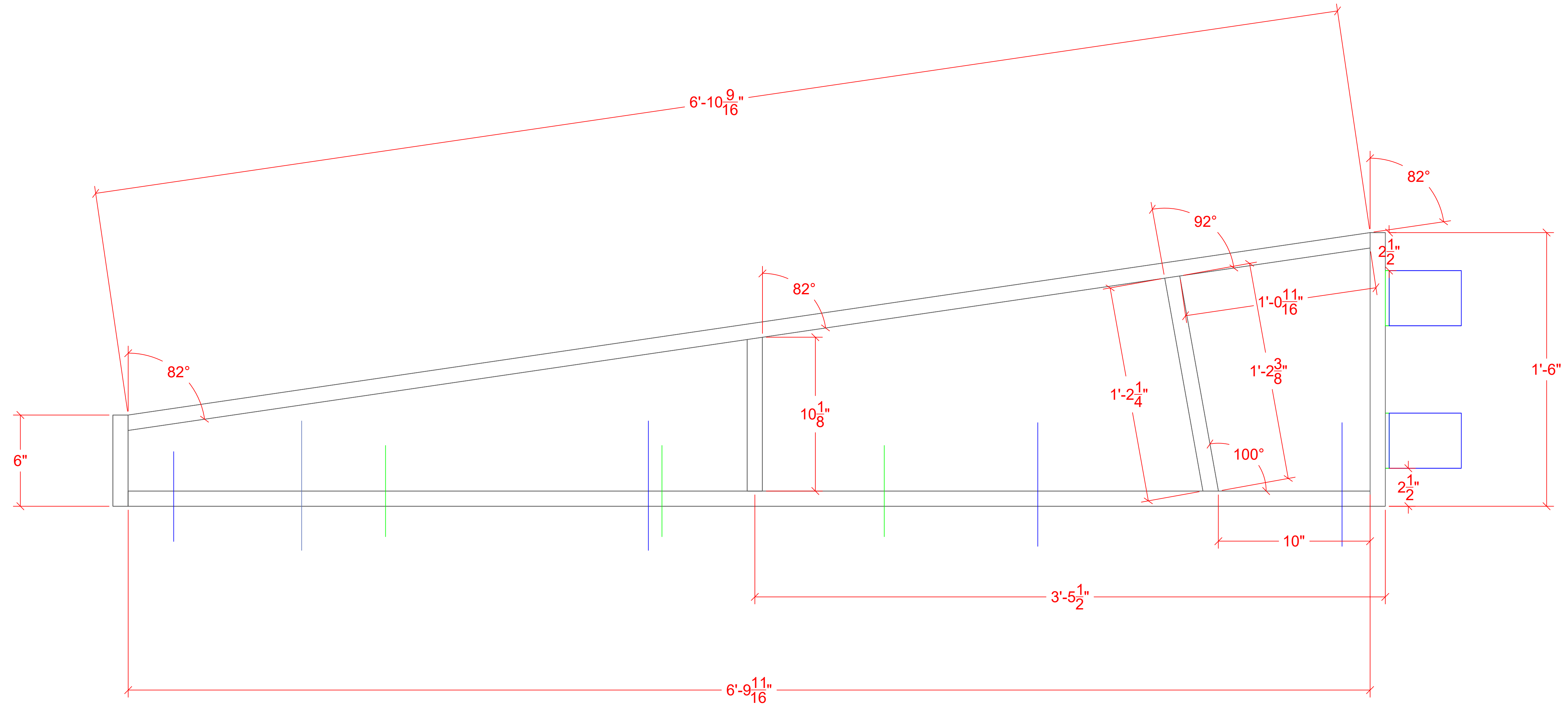
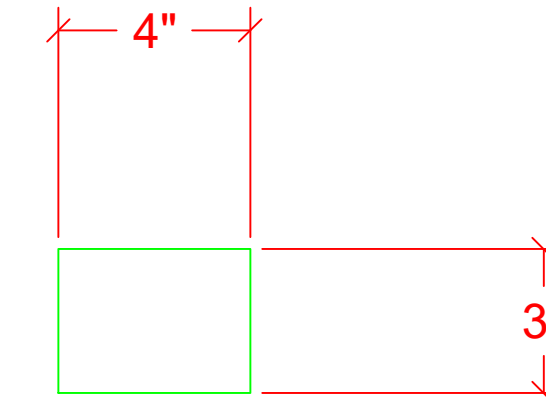

CABARET
Betts
Flat Jacks

Scale:

Date Drawn:

Date Completed:

3" = 1'

Director:

2/28/2022

Designer:

Draftsman:

Gerrad A. Taylor

Michael Stepowany

Abby Bender

CABARET Flat Jacks- MAKE 6

1" box tube construction

Green represents 4" x $\frac{1}{4}$ " flat stock for caster plates- center and drill holes as appropriate

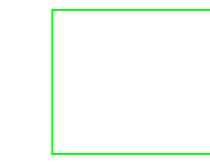

FOUR JACKS GET $\frac{3}{8}$ " HOLES ON THE FOUR BLUE LINES

ONE JACK GETS THE BOTTOM 3 BLUE LINES AND THE GRAY LINE

ONE JACK GETS ONLY THE GREEN LINES

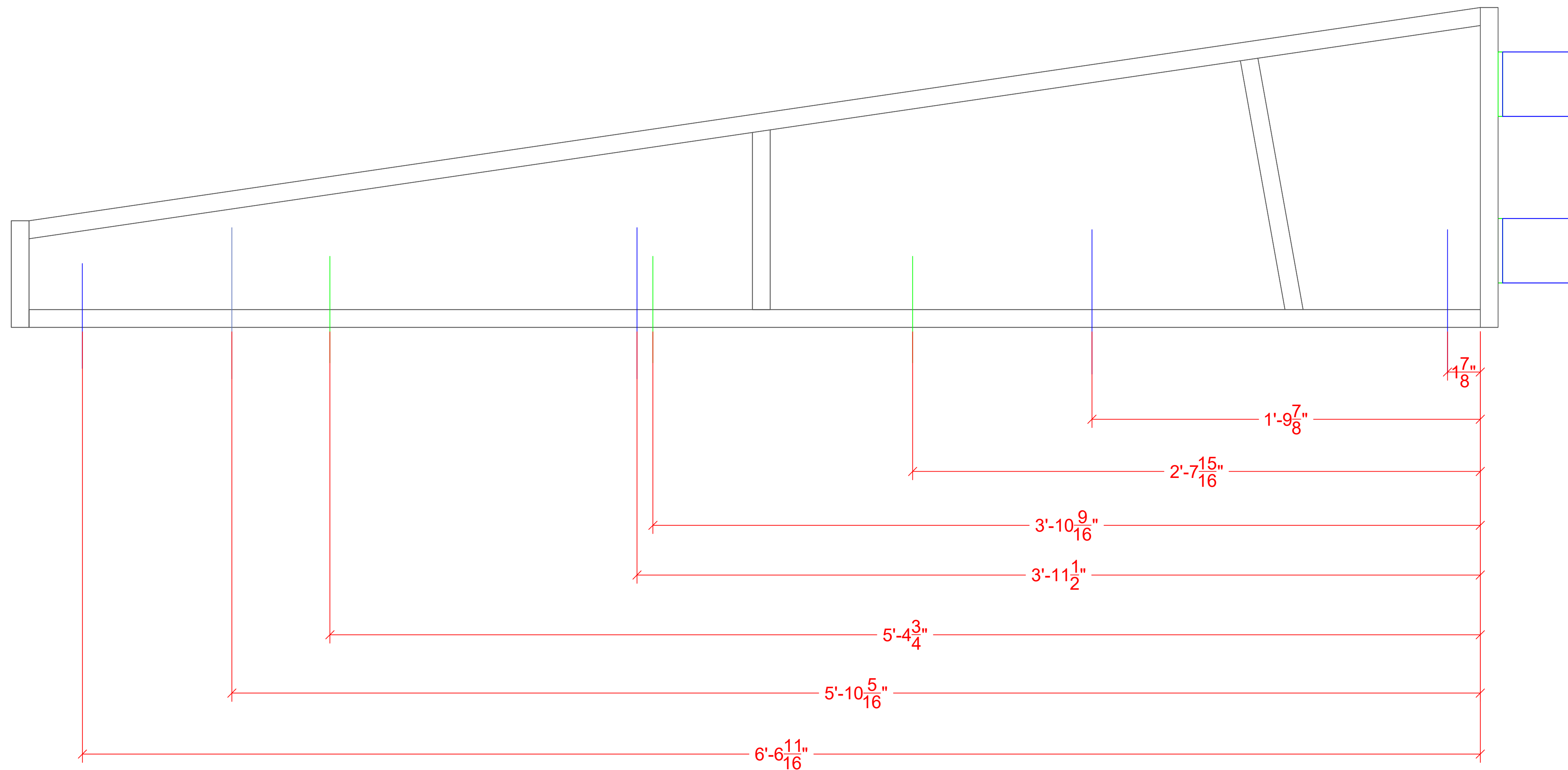

CABARET

Betts

Flat Jacks

Scale:

3" = 1'

Director:

Gerrad A. Taylor

Date Drawn:

2/28/2022

Designer:

Michael Stepowany

Date Completed:

Draftsman:

Abby Bender